

Automatic switch - 2-wires

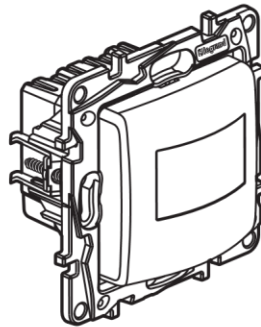

1. USE

Automatic switch without neutral, with infrared detection.
 Switches automatically on in case of movement detection and low natural light level.
 Detection field: 120° - Detection : 8 m
 Supplied with support frame and cover plate.
 Fixing with claws and/or with screws.

2. RANGE

Description	White	Ivory	Brown
Automatic switch 2-wires without neutral, without override To be equipped with plate.	7 645 83	7 646 83	7 647 83

3. DIMENSIONS (mm)

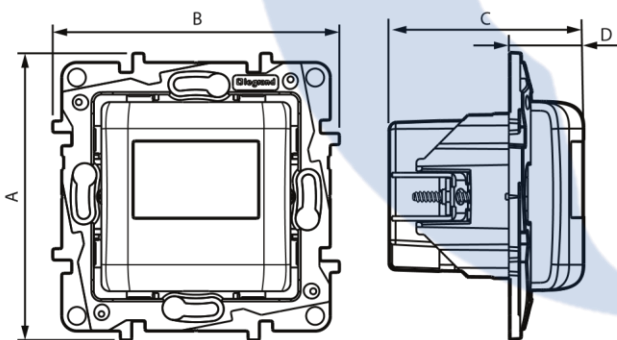

A	B	C	D
76	76	52	20

4. CONNECTION

Number of terminals: 2
 Type of terminals: with screws
 Terminal capacity: 2 x 2.5 mm²
 Stripping length: 8 mm
 Screwdriver: flat 4 mm
 Flexible or rigid cables compatible

5. TECHNICAL CHARACTERISTICS

- **5.1 Mechanical characteristics**
 Protection against solid bodies and liquids: IP 20 (alone)
 IP 41 (assembled product)
 Protection against impact: IK 04
- **5.2 Material characteristics**
 Polyglass appearance
 Colour: - White RAL 9003
 - Ivory RAL 1013
 - Brown
 Material: - Cover plate: ABS
 - Halogen free
 - UV resistant
 Material of the support: - PC grey RAL 7037 + 10 % glass fibre
 - Halogen free
 Self-extinguishing:
 + 850° C / 30 s for insulating parts holding live parts in place
 + 650° C / 30 s for other parts made of insulating materials.
- **5.3 Electrical characteristics**
 - Voltage: 100 - 240 V~
 - Frequency: 50/60 Hz
 - Power accepted by lamp type:
 - LEDs : 3 W to 100 W
 - Fluocompact: 3 W to 100 W
 - LEDs, CFLs, Halogen, with ferromagnetic or electronic ballast: 3 VA à 250 VA
 - Halogen lamps 230 V, incandescent lamps: 3 W to 300 W
 (voir tableau des charges sur e.catalogue)
 - Standby consumption: 0.02 W
 - Time delay adjustable: from 10 s to 10 mn
 - Adjustable luminosity threshold: from 5 Lux to 1275 Lux
- **5.4 Climatic characteristics**
 Storage temperature: - 20° C to + 70° C
 Operating temperature: - 5° C à + 35° C

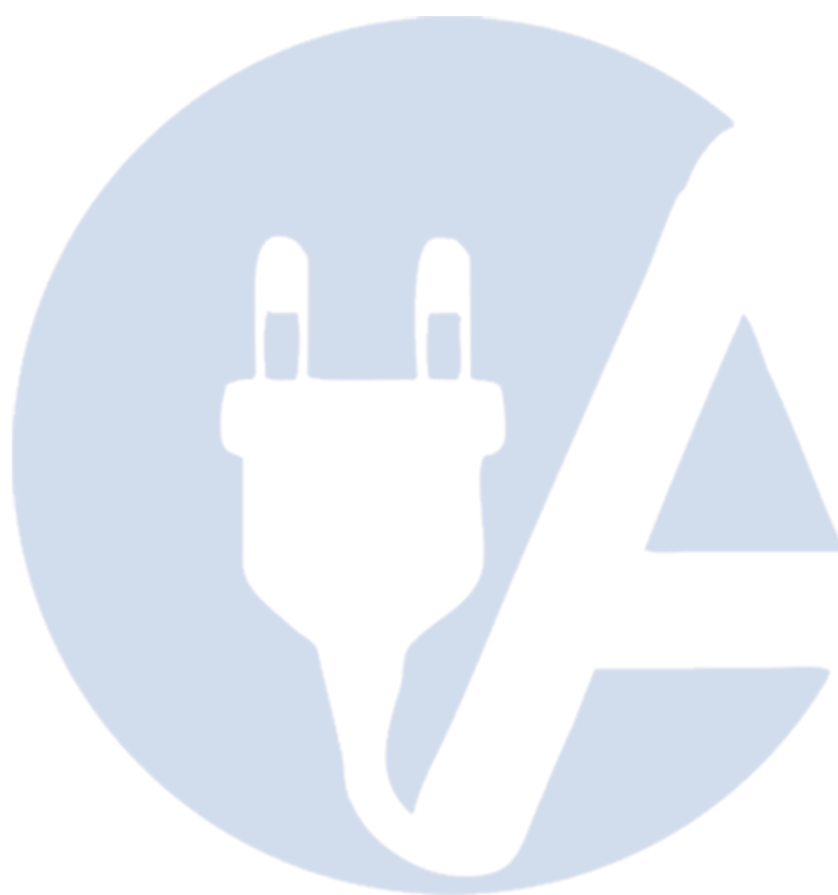

6. CLEANING

Surface cleaning with a cloth.

Do not use: acetone, tar remover, trichlorethylene.

Maintenance with the following products: Hexane (EN 60669-1), Methylated spirit, Soapy water, Diluted ammonia, Bleach diluted to 10%, Window cleaning products.

Caution: A preliminary test should be carried out if other specific cleaning products are to be used.

7. STANDARDS AND APPROVALS

Compliance with standards of installation and manufacturing.

Refer to e. catalogue.

